

THIS DRAWING AND THE INFORMATION CONTAINED HEREON ARE THE PROPERTY OF IMR, Inc. THIS DRAWING IS INTENDED FOR THE SOLE USE OF IMR, Inc., AND ITS AUTHORIZED CLIENTS ONLY.

RC-150 FOR HPC-15 & HPC-15X

NEW CONSTRUCTION BRACKET
FOR COMPRESSION APPLICATIONS
FOR HELI-PILE® HELICAL PILE
HPC-15 & HPC-15X

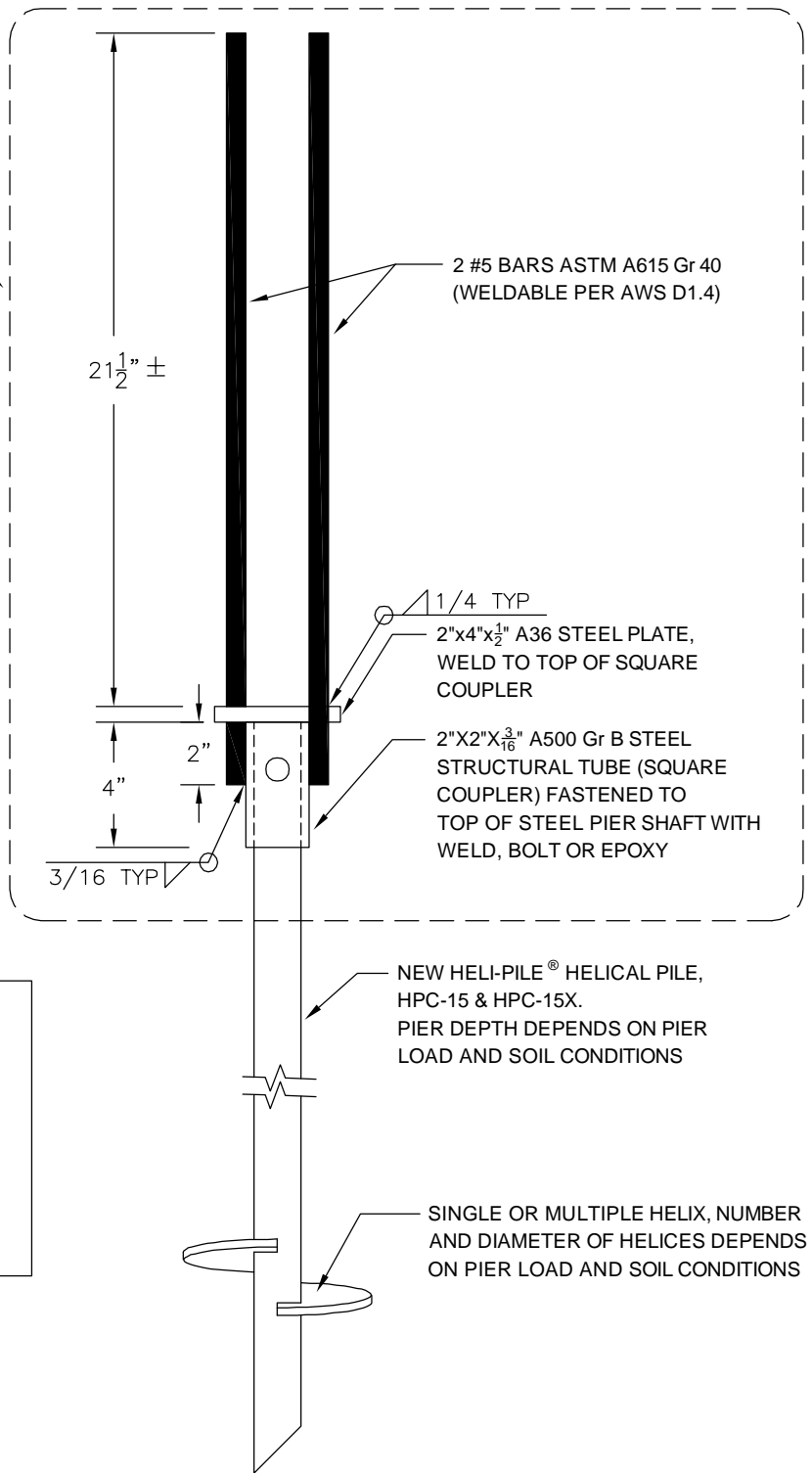

THE ULTIMATE MECHANICAL COMPRESSION CAPACITY OF THIS BRACKET IS 110,000 LBS WHEN BOLTED, WELDED, OR EPOXY GLUED TO THE STEEL PIER SHAFT.

WHEN BOLTED WITH AN SAE J429 Gr 5 $\frac{3}{4}$ " DIAMETER BOLT, EQUAL OR BETTER, THE ULTIMATE MECHANICAL TENSION CAPACITY IS 46,000 LBS

NEW CONSTRUCTION COMPRESSION BRACKET - SQUARE COUPLER FOR HELI-PILE® HPC-15 & HPC-15X HELICAL PILES

NO SCALE

 <p>IMR, Inc. - DENVER 5135 Ward Road, Wheat Ridge, Colorado, 80033 USA 303-423-0591 Fax: 303-423-9155 www.helipile.com</p>	<p>SPECIFICATION SHEET</p>		<p>NEW CONSTRUCTION COMPRESSION BRACKET</p>	
			<p>RC-150.DWG</p>	<p>SHEET 1 OF 1</p>
<p>DRAWN BY: RJV</p>	<p>ENGINEER: JSP</p>	<p>DATE: 6/8/09</p>	<p>REVISION: 0</p>	