

THIS DRAWING AND THE INFORMATION CONTAINED HEREON ARE THE PROPERTY OF IMR, Inc. THIS DRAWING IS INTENDED FOR THE SOLE USE OF IMR, Inc., AND ITS AUTHORIZED CLIENTS ONLY.

RC-150R FOR HPC-15 & HPC-15X

NEW CONSTRUCTION BRACKET
FOR COMPRESSION APPLICATIONS
FOR HELI-PILE® HELICAL PILE
HPC-15 & HPC-15X

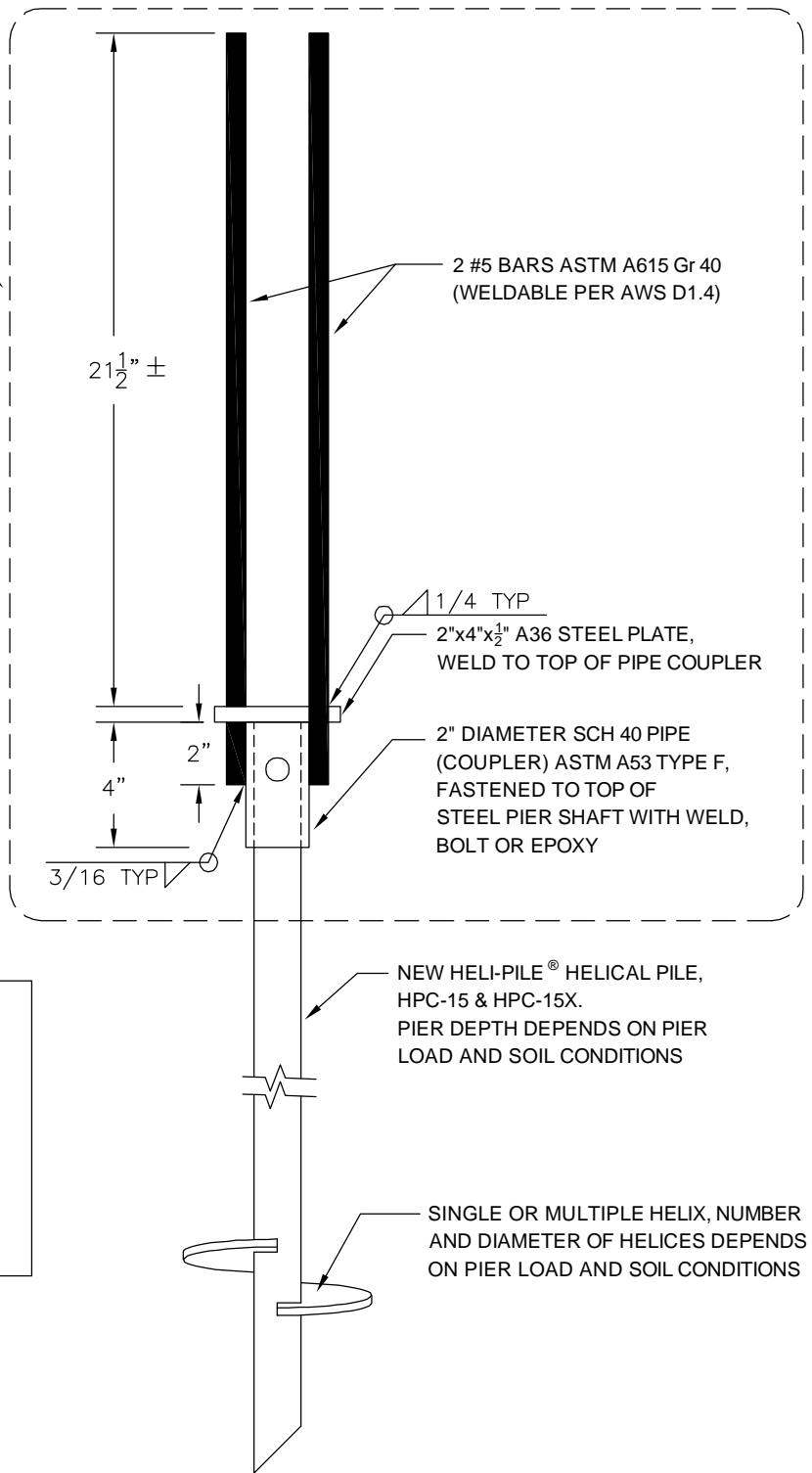

THE ULTIMATE MECHANICAL COMPRESSION CAPACITY OF THIS BRACKET IS 110,000 LBS WHEN BOLTED, WELDED, OR EPOXY GLUED TO THE STEEL PIER SHAFT.

WHEN BOLTED WITH AN SAE J429 Gr 5 3/4" DIAMETER BOLT, EQUAL OR BETTER, THE ULTIMATE MECHANICAL TENSION CAPACITY IS 28,000 LBS

NEW CONSTRUCTION COMPRESSION BRACKET - PIPE COUPLER FOR HELI-PILE® HPC-15 & HPC-15X HELICAL PILES

NO SCALE

 HELI-PILE® IMR, Inc. - DENVER 5135 Ward Road, Wheat Ridge, Colorado, 80033 USA 303-423-0591 Fax: 303-423-9155 www.helipile.com	SPECIFICATION SHEET		NEW CONSTRUCTION COMPRESSION BRACKET	
	DRAWN BY: RJV	ENGINEER: JSP	DATE: 6/8/09	SHEET 1 OF 1 REVISION: 0