

THIS DRAWING AND THE INFORMATION CONTAINED HEREON ARE THE PROPERTY OF IMR, Inc. THIS DRAWING IS INTENDED FOR THE SOLE USE OF IMR, Inc., AND ITS AUTHORIZED CLIENTS ONLY.

UP-150

UNDERPINNING BRACKET

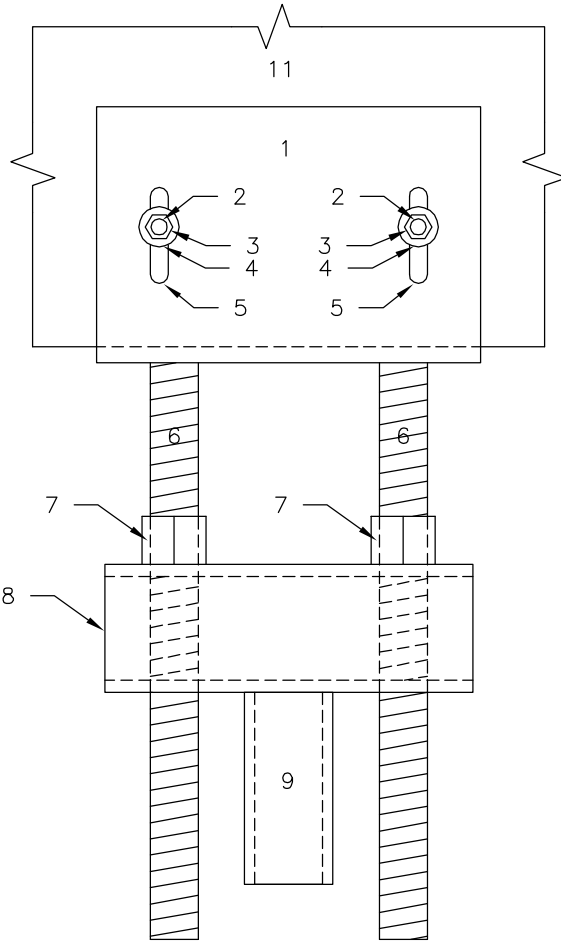

FRONT ELEVATION
NO SCALE

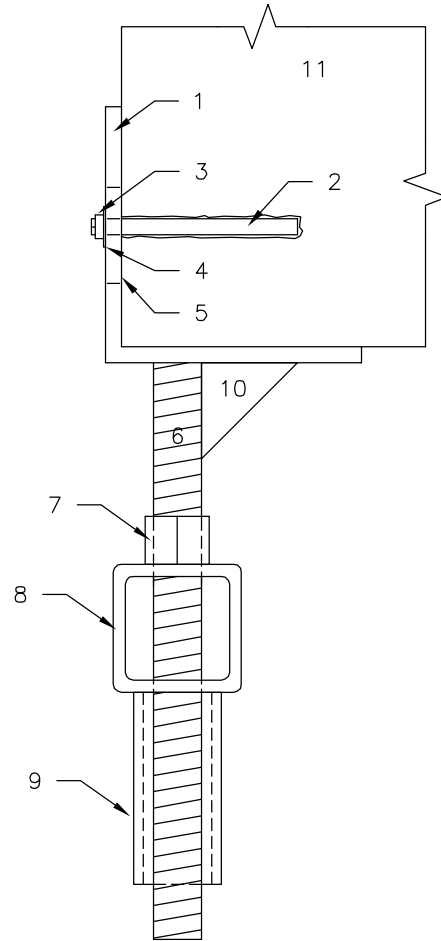

SIDE ELEVATION
NO SCALE

1. STRUCTURAL ANGLE: 8" X 8" X $\frac{1}{2}$ ", 12" LONG
2. CONCRETE EXPANSION BOLT: $\frac{1}{2}$ " X 5- $\frac{1}{2}$ " REDHEAD OR EQ.
3. NUT ON EXPANSION BOLT
4. WASHER ON EXPANSION BOLT
5. SLOTTED HOLE: 3" X $\frac{9}{16}$ "
6. THREAD ROD: 1- $\frac{1}{2}$ " WILLIAMS GR 75, 18" LONG
7. NUT: 1- $\frac{1}{2}$ "
8. STRUCTURAL TUBE: 4" X 4" X $\frac{3}{8}$ ", 11.5" LONG
9. PIPE SLEEVE: CARBON MECHANICAL TUBING:
2.75" OD, 2.125" ID, 0.313" WALL TH., 6" LONG
10. GUSSET PLATE: 3" X 3" X $\frac{1}{2}$ "
11. CONCRETE FOOTING OR GRADE BEAM

NOTE: ALL ANGLE STEEL, PLATE STEEL, & STRUCTURAL TUBING IS A36.
ALL PIPE IS 35 KSI MIN YIELD.
ULTIMATE CAPACITY 200,000 LBS

U.S. PATENT NO. 5,800,094

HELI-PILE®



IMR, Inc. - DENVER
5135 Ward Road, Wheat Ridge, Colorado, 80033 USA
303-423-0591 Fax: 303-423-9155
www.helipile.com

**SPECIFICATION
SHEET**

**UP-150 UNDERPINNING
BRACKET**

DRAWN BY: RJV ENGINEER: JSP

UP-150.DWG SHEET 1 OF 1
DATE: 05/19/09 REVISION: 1